

3111

Mat = C45
Max T/m = 100
 $\alpha = 85^\circ$

1000 mm	21,0 kg
500 mm	10,0 kg
1100 mm FRAZ. / SECT.	21,0 kg
100 mm	2,0 kg

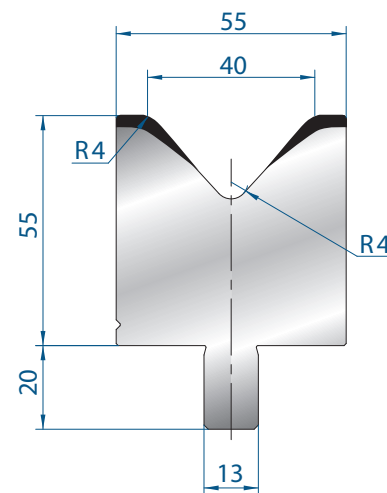

3112

Mat = C45
Max T/m = 100
 $\alpha = 85^\circ$

1000 mm	21,0 kg
500 mm	10,0 kg
1100 mm FRAZ. / SECT.	21,0 kg
100 mm	2,0 kg