

25-30	
35-40 mm	3,6 kg
45-50	
100 mm	9,1 kg
200 mm	18,2 kg
550 mm	50,0 kg
FRAZ. / SECT.	
1050 mm	95,5 kg
FRAZ. B / SECT. B	
1250 mm	113,7 kg
FRAZ. B / SECT. B	
2050 mm	186,5 kg
FRAZ. B / SECT. B	
2550 mm	232,0 kg
FRAZ. B / SECT. B	
3050 mm	277,5 kg
FRAZ. B / SECT. B	
4050 mm	368,5 kg
FRAZ. B / SECT. B	

3224

**Mat** = 42CrMo4  
bonificato / tempered

**Max T/m** = 160

**$\alpha$**  = 60°



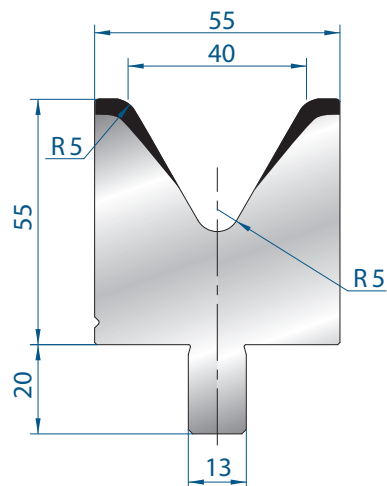

3113

Mat = C45  
Max T/m = 100  
 $\alpha = 60^\circ$

1000 mm	20,0 kg
500 mm	10,0 kg
1100 mm FRAZ. / SECT.	20,0 kg
100 mm	2,0 kg

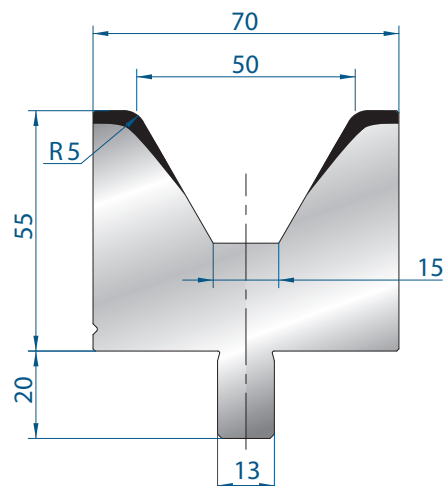

3179

Mat = C45  
Max T/m = 100  
 $\alpha = 60^\circ$

1000 mm	24,0 kg
500 mm	12,0 kg
1100 mm FRAZ. / SECT.	24,0 kg
100 mm	2,4 kg

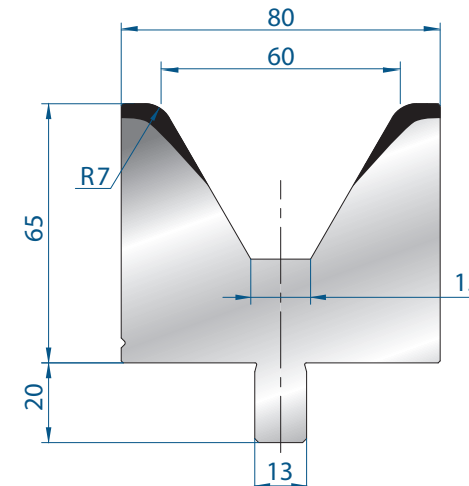

3114

Mat = C45  
Max T/m = 100  
 $\alpha = 60^\circ$

1000 mm	31,0 kg
500 mm	15,0 kg
1100 mm FRAZ. / SECT.	31,0 kg
100 mm	3,0 kg