

# DIMPLE TOOL

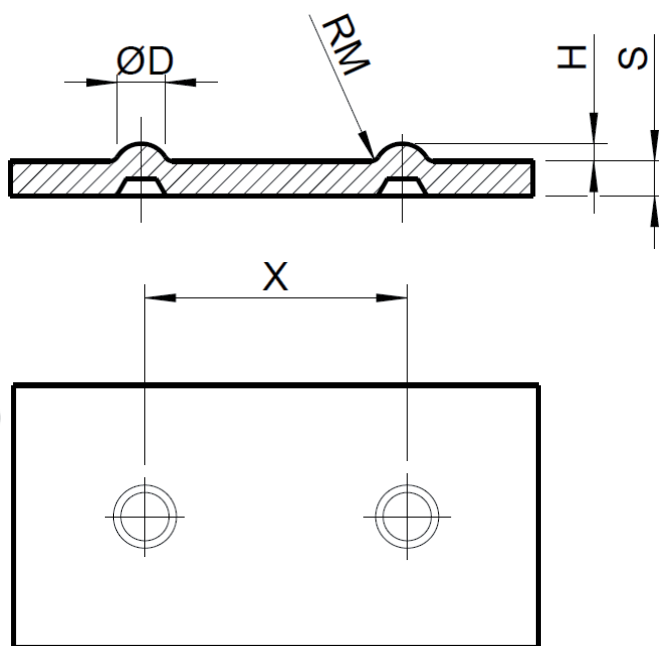

TRUMPF

THICK TURRET

SALVAGNINI

## BASIC INFORMATION

Material:	
Sheet thickness „s“:	
Machine:	
Size/station:	
Direction of forming:	upform <input type="checkbox"/>
	downform <input type="checkbox"/>
Customer information:	

## TOOL INFORMATION IN MM

$\varnothing D$ :	
H:	
RM:	Standard: 0.2 mm
X:	Standard: 15 mm