

COUNTERSINK TOOL

TRUMPF
THICK TURRET
SALVAGNINI

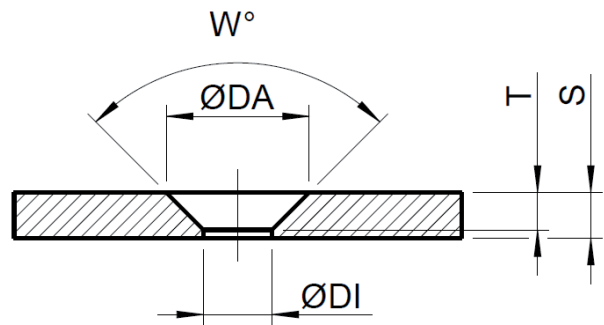

	90°-SINKING		120°-SINKING	
	min. cyl. part	max. sinking depth	min. cyl. part	max. sinking depth
Aluminium	0.25 mm	90% of s	0.35 mm	80% of s
Steel	0.25 mm	80% of s	0.35 mm	70% of s
Stainless steel	0.5 mm	66% of s	0.7 mm	50% of s

BASIC INFORMATION	
Material:	
Sheet thickness „s“:	
Machine:	
Size/station:	
Direction of forming:	<input type="checkbox"/> upform <input type="checkbox"/> downform
Customer information:	

TOOL INFORMATION IN MM				
øDA:				
øDI:				
W in °:				
T:				
<input type="checkbox"/> DIN				
<input type="checkbox"/> M2	<input type="checkbox"/> M2.5	<input type="checkbox"/> M3	<input type="checkbox"/> M4	
<input type="checkbox"/> M5	<input type="checkbox"/> M5.5	<input type="checkbox"/> M6	<input type="checkbox"/> M8	
<input type="checkbox"/> ST2.2	<input type="checkbox"/> ST2.9	<input type="checkbox"/> ST3.5	<input type="checkbox"/> ST4.2	
<input type="checkbox"/> ST4.8	<input type="checkbox"/> ST5.5	<input type="checkbox"/> ST6.3	<input type="checkbox"/> ST8	

Order_forms_Special_Tools 02/2017 Version 1.0