

CONTINUOUS BEADING TOOL

TRUMPF

THICK TURRET

SALVAGNINI

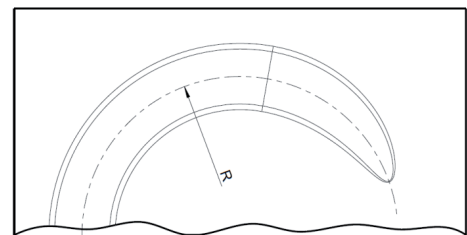
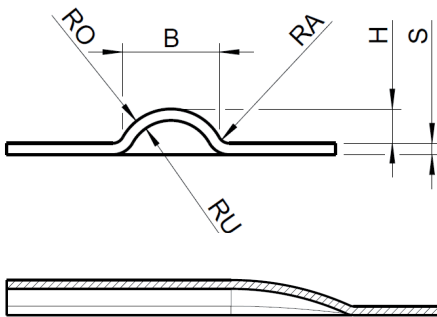

Tool distance / stroke $\approx 1 - 5$ mm
 We advice $B_{min} = 3 \times H$ for an optimum forming

BASIC INFORMATION	
Material:	
Sheet thickness „s“:	
Machine:	
Size/station:	
Direction of forming:	upform <input type="checkbox"/>
	downform <input type="checkbox"/>
Customer information:	

TOOL INFORMATION IN MM	
B:	
RO:	
RU:	
RA:	
H:	
Beading shape:	
Straight <input type="checkbox"/>	Circular <input type="checkbox"/>
R:	

Order_forms_Special_Tools 02/2017 Version 1.0