

PASS SYSTEM STANDARD (COMPACT VERSION)

TYPE: 33 MM / 70 KN / P1 - P20

MAX. DIAMETER: 33 MM

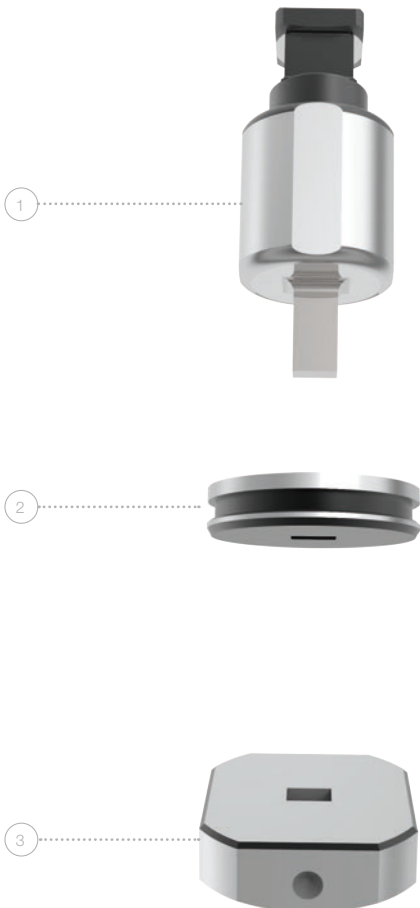

	POS.-NO.	PART-NO.
PUNCH (H-PM®)		
Round	1	201301
Square	1	2013002
Rectangle	1	2013003
Oblong	1	2013004
O.D. Ground Special Shape	1	21530G
EDM Required Special Shape	1	21530E
STRIPPER		
Round	2	210301
Square	2	2103002
Rectangle	2	2103003
Oblong	2	2103004
O.D. Ground Special Shape	2	21730G
EDM Required Special Shape	2	21730E
DIE (SLUG-STOP) (H-PM®)		
Round	3	206301
Square	3	2063002
Rectangle	3	2063003
Oblong	3	2063004
O.D. Ground Special Shape	3	21630G
EDM Required Special Shape	3	21630E

SPARE PARTS		ADDITIONAL COSTS FOR PUNCH
Shims for die t = 0,3	203A33	TICN coating
Shims for die t = 0,5	205A35	T-MAX coating
		A-MAX coating
		Cutting part under 1,00 mm
		ADDITIONAL COSTS FOR STRIPPER
		Polypunch
		ADDITIONAL COSTS FOR DIES
		Reinforced
		slug-snap

PASS SYSTEM P1 (NEEDLE INSERT)

TYPE: 33 MM / 70 KN / P1 - P20

MAX. DIAMETER: 6 MM

	POS.-NO.	PARTNO.
UPPER PART		
Round	1-3	201401
Square	---	---
Rectangle	---	---
Oblong	---	---
O.D. Ground Special Shape	---	---
EDM Required Special Shape	---	---
PUNCH CHUCK		
Round	1+2	219401
PUNCH INSERT (SHAFT Ø 6 MM) (H-PM®)		
Round	3	207P1A1
Square	---	---
Rectangle	---	---
Oblong	---	---
O.D. Ground Special Shape	---	---
EDM Required Special Shape	---	---
STRIPPER		
Round	4	210301
Square	---	---
Rectangle	---	---
Oblong	---	---
O.D. Ground Special Shape	---	---
EDM Required Special Shape	---	---
DIE (SLUG-STOP) (H-PM®)		
Round	5	206301
Square	---	---
Rectangle	---	---
Oblong	---	---
O.D. Ground Special Shape	---	---
EDM Required Special Shape	---	---

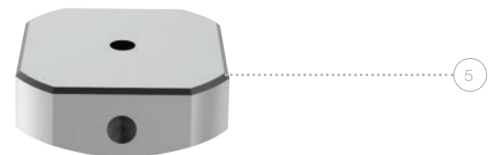
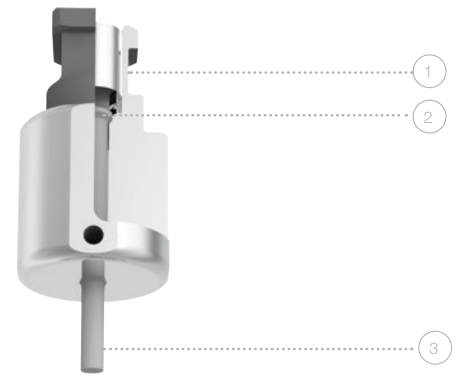

ADDITIONAL COSTS FOR PUNCH

TICN coating
 T-MAX coating
 A-MAX coating
 Cutting part under 1,00 mm

ADDITIONAL COSTS FOR STRIPPER

Polypunch

ADDITIONAL COSTS FOR DIES

Reinforced
 slug-snap

SPARE PARTS

Retaining screw	2	219403
Shims for die t = 0,3		203A33
Shims for die t = 0,5		205A35

PASS SYSTEM P1 (NEEDLE INSERT)

TYPE: 33 MM / 70 KN / P1 - P20

MAX. DIAMETER: 10,5 MM

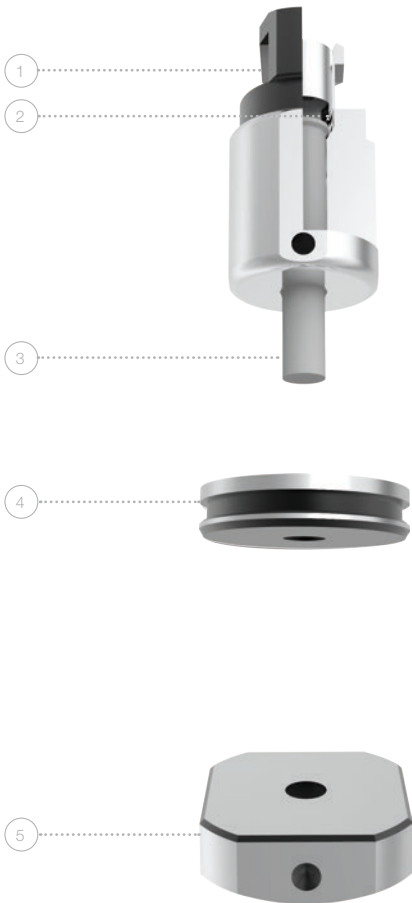

	POS.-NO.	PART-NO.
UPPER PART		
Round	1-3	201421
Square	---	---
Rectangle	---	---
Oblong	---	---
O.D. Ground Special Shape	---	---
EDM Required Special Shape	---	---

PUNCH CHUCK		
Round	1+2	219421

PUNCH INSERT (SHAFT Ø 10,5 MM) (H-PM®)		
Round	3	207P1B1
Square	---	---
Rectangle	---	---
Oblong	---	---
O.D. Ground Special Shape	---	---
EDM Required Special Shape	---	---

STRIPPER		
Round	4	210301
Square	---	---
Rectangle	---	---
Oblong	---	---
O.D. Ground Special Shape	---	---
EDM Required Special Shape	---	---

DIE (SLUG-STOP) (H-PM®)		
Round	5	206301
Square	---	---
Rectangle	---	---
Oblong	---	---
O.D. Ground Special Shape	---	---
EDM Required Special Shape	---	---

SPARE PARTS			ADDITIONAL COSTS FOR PUNCH		
Retaining screw	2	219423	TICN coating		
Shims for die t = 0,3		203A33	T-MAX coating		
Shims for die t = 0,5		205A35	A-MAX coating		

ADDITIONAL COSTS FOR STRIPPER		
Polypunch		

ADDITIONAL COSTS FOR DIES		
Reinforced		
slug-snap		

PASS SYSTEM P2 (FOR 2 MM REGRINDING LENGTH)

TYPE: 33 MM / 70 KN / P1 - P20

MAX. DIAMETER: 16 MM

	POS.-NO.	PART-NO.
UPPER PART		
Round	1-4	201441
Square	1-4	2014402
Rectangle	1-4	2014403
Oblong	1-4	2014404
O.D. Ground Special Shape	1-4	21544G
EDM Required Special Shape	1-4	21544E
PUNCH CHUCK		
For all shapes	1-3	219441
PUNCH INSERT (H-PM®)		
Round	4	207P2A1
Square	4	207P2A02
Rectangle	4	207P2A03
Oblong	4	207P2A04
O.D. Ground Special Shape	4	207P2AG
EDM Required Special Shape	4	207P2AE
STRIPPER		
Round	5	210301
Square	5	2103002
Rectangle	5	2103003
Oblong	5	2103004
O.D. Ground Special Shape	5	21730G
EDM Required Special Shape	5	21730E
DIE (SLUG-STOP) (H-PM®)		
Round	6	206301
Square	6	2063002
Rectangle	6	2063003
Oblong	6	2063004
O.D. Ground Special Shape	6	21630G
EDM Required Special Shape	6	21630E

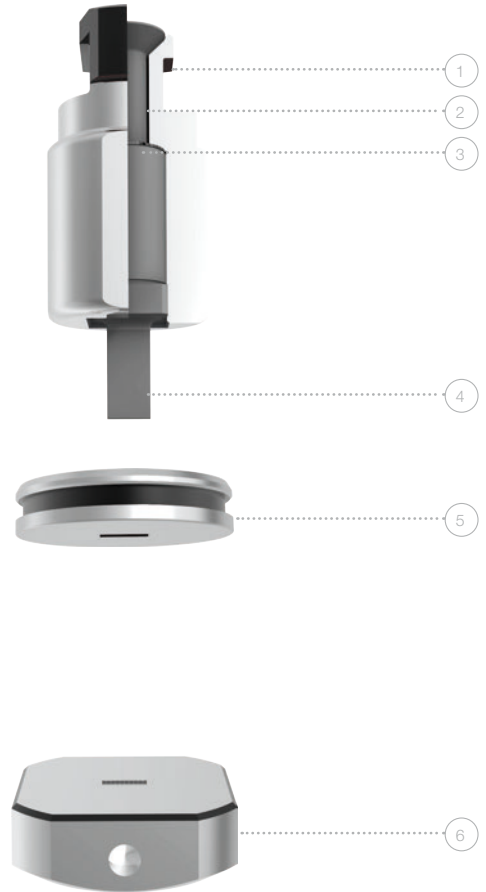

ADDITIONAL COSTS FOR PUNCH

TICN coating
T-MAX coating
A-MAX coating
Cutting part under 1,00 mm

ADDITIONAL COSTS FOR STRIPPER

Polypunch

ADDITIONAL COSTS FOR DIES

Reinforced
slug-snap

SPARE PARTS

Retaining screw	2	219444
Set shims for punch chuck (4 x 0,5 mm)	3	219443
Shims for die t = 0,3		203A33
Shims for die t = 0,5		205A35

PASS SYSTEM P4 (BLANK-HOLDER STYLE AND NEEDLE INSERT)

TYPE: 33 MM / 70 KN / P1 - P20

MAX. DIAMETER: 6 MM

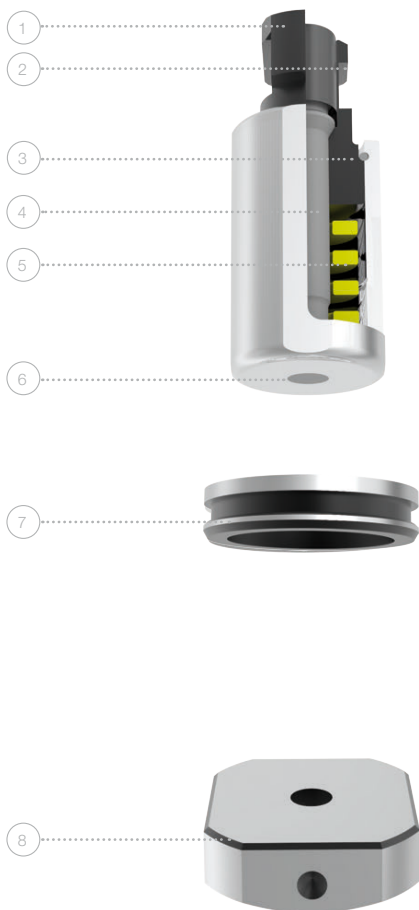

	POS.-NO.	PART-NO.
UPPER PART		
Round	1-6	201521
Square	---	---
Rectangle	---	---
Oblong	---	---
O.D. Ground Special Shape	---	---
EDM Required Special Shape	---	---
PUNCH INSERT (SHAFT Ø 6 MM) (H-PM®)		
Round	4	207P4A1
Square	---	---
Rectangle	---	---
Oblong	---	---
O.D. Ground Special Shape	---	---
EDM Required Special Shape	---	---
ACTIVE STRIPPER		
Round	6+3	219525
Square	---	---
Rectangle	---	---
Oblong	---	---
O.D. Ground Special Shape	---	---
EDM Required Special Shape	---	---
STRIPPER		
Round 35 mm	7	210335
DIE (SLUG-STOP) (H-PM®)		
Round	8	206301
Square	---	---
Rectangle	---	---
Oblong	---	---
O.D. Ground Special Shape	---	---
EDM Required Special Shape	---	---

SPARE PARTS			ADDITIONAL COSTS FOR PUNCH	
Punch head	1+2	219521	TICN coating	
Retaining screw	2	219528	T-MAX coating	
Locking ring	3	219527	A-MAX coating	
Spring	5	219526	Cutting part under 1,00 mm	
Shims for die t = 0,3		203A33	ADDITIONAL COSTS FOR STRIPPER	
Shims for die t = 0,5		205A35	Polypunch	
ADDITIONAL ACCESSORIES			ADDITIONAL COSTS FOR DIES	
Assembly adapter		299201599	Reinforced	
			slug-snap	

PASS SYSTEM P4 (BLANK-HOLDER STYLE AND NEEDLE INSERT)

TYPE: 33 MM / 70 KN / P1 - P20

MAX. DIAMETER: 10,5 MM

	POS.-NO.	PART-NO.
UPPER PART		
Round	1-6	201561
Square	---	---
Rectangle	---	---
Oblong	---	---
O.D. Ground Special Shape	---	---
EDM Required Special Shape	---	---
PUNCH INSERT (SHAFT Ø 10,5 MM) (H-PM®)		
Round	4	207P4B1
Square	---	---
Rectangle	---	---
Oblong	---	---
O.D. Ground Special Shape	---	---
EDM Required Special Shape	---	---
ACTIVE STRIPPER		
Round	6+3	219525
Square	---	---
Rectangle	---	---
Oblong	---	---
O.D. Ground Special Shape	---	---
EDM Required Special Shape	---	---
STRIPPER		
Round 35 mm	7	210335
DIE (SLUG-STOP) (H-PM®)		
Round	8	206301
Square	---	---
Rectangle	---	---
Oblong	---	---
O.D. Ground Special Shape	---	---
EDM Required Special Shape	---	---

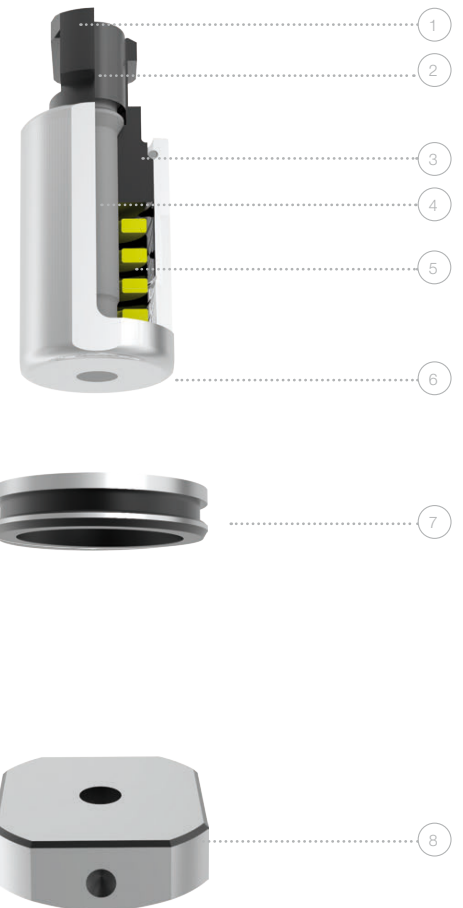

ADDITIONAL COSTS FOR PUNCH	SPARE PARTS
TICN coating	Punch head 1+2 219522
T-MAX coating	Retaining screw 2 219528
A-MAX coating	Locking ring 3 219527
Cutting part under 1,00 mm	Spring 5 219526
ADDITIONAL COSTS FOR STRIPPER	Shims for die t = 0,3 203A33
Polypunch	Shims for die t = 0,5 205A35
ADDITIONAL COSTS FOR DIES	ADDITIONAL ACCESSORIES
Reinforced slug-snap	Assembly adapter 299201599

PASS SYSTEM P5 (BLANK-HOLDER STYLE AND PUNCH INSERT)

TYPE: 33 MM / 70 KN / P1 - P20

MAX. DIAMETER: 12,5 MM

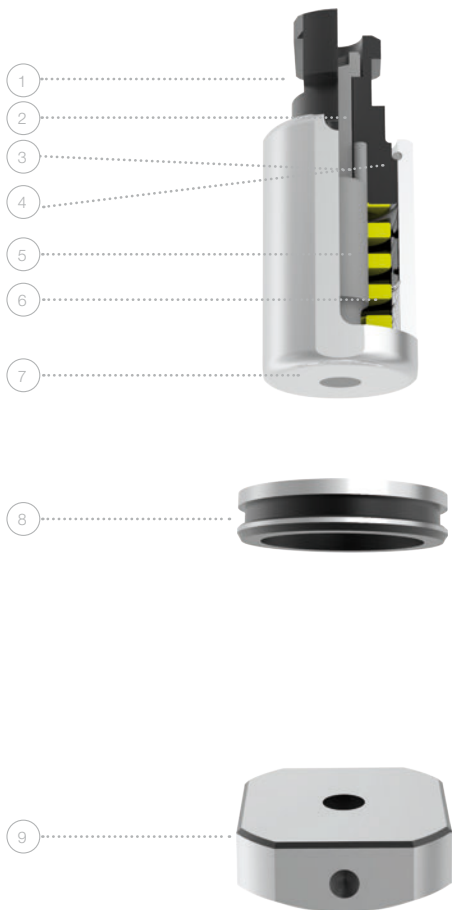

	POS.-NO.	PART-NO.
UPPER PART		
Round	1-7	201531
Square	---	---
Rectangle	---	---
Oblong	---	---
O.D. Ground Special Shape	---	---
EDM Required Special Shape	---	---
PUNCH INSERT (H-PM®)		
Round	5	207P5A1
Square	---	---
Rectangle	---	---
Oblong	---	---
O.D. Ground Special Shape	---	---
EDM Required Special Shape	---	---
ACTIVE STRIPPER		
Round	7+4	219534
Square	---	---
Rectangle	---	---
Oblong	---	---
O.D. Ground Special Shape	---	---
EDM Required Special Shape	---	---
STRIPPER		
Round 35 mm	8	210335
DIE (SLUG-STOP) (H-PM®)		
Round	9	206301
Square	---	---
Rectangle	---	---
Oblong	---	---
O.D. Ground Special Shape	---	---
EDM Required Special Shape	---	---

SPARE PARTS			ADDITIONAL COSTS FOR PUNCH	
Punch head	1-3	219532	TICN coating	
Retaining screw	2	219537	T-MAX coating	
Pin	3	219538	A-MAX coating	
Locking ring	4	219536	Cutting part under 1,00 mm	
Spring	6	219535	ADDITIONAL COSTS FOR STRIPPER	
Shims for die t = 0,3		203A33	Polypunch	
Shims for die t = 0,5		205A35	ADDITIONAL COSTS FOR DIES	
ADDITIONAL ACCESSORIES			Reinforced	
Assembly adapter		299201599	slug-snap	

PASS SYSTEM P6 (BLANK-HOLDER STYLE AND PUNCH INSERT)

TYPE: 33 MM / 70 KN / P1 - P20

MAX. DIAMETER: 12,5 MM

	POS.-NO.	PARTNO.
UPPER PART		
Round	---	---
Square	1-7	2015102
Rectangle	1-7	2015103
Oblong	1-7	2015104
O.D. Ground Special Shape	1-7	20151G
EDM Required Special Shape	1-7	20151E
PUNCH INSERT (H-PM®)		
Round	---	---
Square	5	207P6A02
Rectangle	5	207P6A03
Oblong	5	207P6A04
O.D. Ground Special Shape	5	207P6AG
EDM Required Special Shape	5	207P6AE
ACTIVE STRIPPER		
Round	---	---
Square	7+4	2195102
Rectangle	7+4	2195103
Oblong	7+4	2195104
O.D. Ground Special Shape	7+4	21951G
EDM Required Special Shape	7+4	21951E
STRIPPER		
Round 35 mm	8	210335
DIE (SLUG-STOP) (H-PM®)		
Round	---	---
Square	9	2063002
Rectangle	9	2063003
Oblong	9	2063004
O.D. Ground Special Shape	9	21630G
EDM Required Special Shape	9	21630E

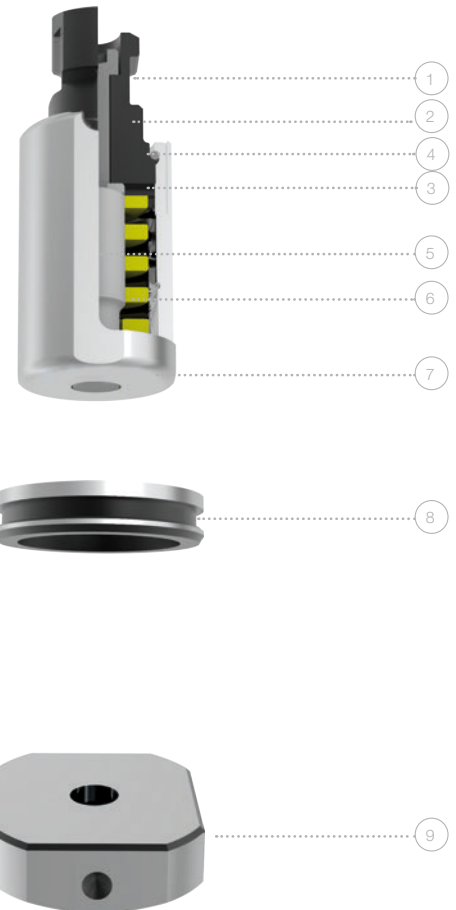

ADDITIONAL COSTS FOR PUNCH	SPARE PARTS
TICN coating	Punch head 1-3 219511
T-MAX coating	Retaining screw 2 219512
A-MAX coating	Location pin 3 219513
Cutting part under 1,00 mm	Locking ring 4 219514
ADDITIONAL COSTS FOR STRIPPER	Spring 6 219516
Polypunch	Shims for die t = 0,3 203A33
	Shims for die t = 0,5 205A35
ADDITIONAL COSTS FOR DIES	ADDITIONAL ACCESSORIES
Reinforced slug-snap	Assembly adapter 299201599

PASS SYSTEM P7 (BLANK-HOLDER STYLE AND PUNCH INSERT)

TYPE: 33 MM / 70 KN / P1 - P20

DIAMETER: UP TO 26 MM



POS.-NO.

PART-NO.

UPPER PART			
Round	1-8	201551	
Square	1-8	2015502	
Rectangle	1-8	2015503	
Oblong	1-8	2015504	
O.D. Ground Special Shape	1-8	20155G	
EDM Required Special Shape	1-8	20155E	

PUNCH INSERT (H-PM®)			
Round	3	207P7B1	
Square	3	207P7B02	
Rectangle	3	207P7B03	
Oblong	3	207P7B04	
O.D. Ground Special Shape	3	207P7BG	
EDM Required Special Shape	3	207P7BE	

ACTIVE STRIPPER			
Round	8+7	219552	
Square	8+7	2195502	
Rectangle	8+7	2195503	
Oblong	8+7	2195504	
O.D. Ground Special Shape	8+7	21955G	
EDM Required Special Shape	8+7	21955E	

STRIPPER			
Round 35 mm	9	210335	

DIE (SLUG-STOP) (H-PM®)			
Round	10	206301	
Square	10	2063002	
Rectangle	10	2063003	
Oblong	10	2063004	
O.D. Ground Special Shape	10	21630G	
EDM Required Special Shape	10	21630E	

SPARE PARTS			ADDITIONAL COSTS FOR PUNCH		
Punch head	1+2+4	219551	TICN coating		
Retaining screw	2	219553	T-MAX coating		
Location pin	4	219556	A-MAX coating		
Spring	5	219557	Cutting part under 1,00 mm		
Spacer	6	219558			
Locking ring	7	219559			
Shims for die t = 0,3		203A33			
Shims for die t = 0,5		205A35			
ADDITIONAL ACCESSORIES			ADDITIONAL COSTS FOR STRIPPER		
Assembling circlip pliers		220300	Polypunch		
Assembling pin		220994			
			ADDITIONAL COSTS FOR DIES		
			Reinforced		
			slug-snap		

PASS SYSTEM P8 (PUNCH INSERT)

TYPE: 33 MM / 70 KN / P1 - P20

DIAMETER: UP TO 33 MM

	POS.-NO.	PART-NO.
UPPER PART		
Round	1-3	201651
Square	1-3	2016502
Rectangle	1-3	2016503
Oblong	1-3	2016504
O.D. Ground Special Shape	1-3	21565G
EDM Required Special Shape	1-3	21565E
PUNCH HOLDER		
For all shapes	1+2	219651
PUNCH INSERT (H-PM®)		
Round	3	207P8B1
Square	3	207P8B02
Rectangle	3	207P8B03
Oblong	3	207P8B04
O.D. Ground Special Shape	3	207P8BG
EDM Required Special Shape	3	207P8BE
STRIPPER		
Round	4	210301
Square	4	2103002
Rectangle	4	2103003
Oblong	4	2103004
O.D. Ground Special Shape	4	21730G
EDM Required Special Shape	4	21730E
DIE (SLUG-STOP) (H-PM®)		
Round	5	206301
Square	5	2063002
Rectangle	5	2063003
Oblong	5	2063004
O.D. Ground Special Shape	5	21630G
EDM Required Special Shape	5	21630E

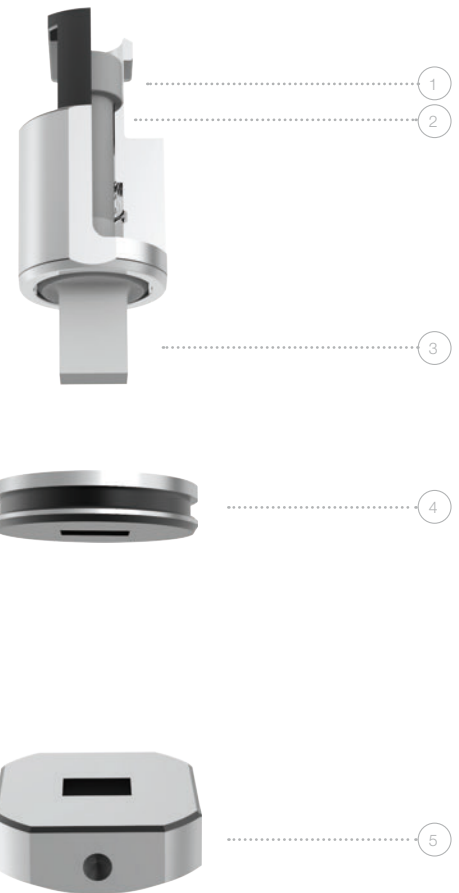

ADDITIONAL COSTS FOR PUNCH

TICN coating
T-MAX coating
A-MAX coating
Cutting part under 1,00 mm

SPARE PARTS

Retaining screw	2	219654
Shims for die t = 0,3		203A33
Shims for die t = 0,5		205A35

ADDITIONAL COSTS FOR STRIPPER

Polypunch

ADDITIONAL COSTS FOR DIES

Reinforced
slug-snap

PASS SYSTEM P9 (BLANK-HOLDER STYLE AND PUNCH INSERT)

TYPE: 33 MM / 70 KN / P1 - P20

DIAMETER: UP TO 26,5 MM



POS.-NO.

PART-NO.

UPPER PART			
Round	1-8	201571	
Square	1-8	2015702	
Rectangle	1-8	2015703	
Oblong	1-8	2015704	
O.D. Ground Special Shape	1-8	20157G	
EDM Required Special Shape	1-8	20157E	

PUNCH INSERT (H-PM®)			
Round	6	207P9B1	
Square	6	207P9B02	
Rectangle	6	207P9B03	
Oblong	6	207P9B04	
O.D. Ground Special Shape	6	207P9BG	
EDM Required Special Shape	6	207P9BE	

ACTIVE STRIPPER			
Round	8+3	219571	
Square	8+3	2195702	
Rectangle	8+3	2195703	
Oblong	8+3	2195704	
O.D. Ground Special Shape	8+3	21957G	
EDM Required Special Shape	8+3	21957E	

STRIPPER			
Round 35 mm	9	210335	

DIE (SLUG-STOP) (H-PM®)			
Round	10	206301	
Square	10	2063002	
Rectangle	10	2063003	
Oblong	10	2063004	
O.D. Ground Special Shape	10	21630G	
EDM Required Special Shape	10	21630E	

SPARE PARTS			ADDITIONAL COSTS FOR PUNCH		
Punch head	1+2+4	219572	TICN coating		
Retaining screw	2	219573	T-MAX coating		
Location pin	4	219576	A-MAX coating		
Spring	5	219577	Cutting part under 1,00 mm		
Spacer	7	219578			
Locking ring	3	219579			
Shims for die t = 0,3		203A33			
Shims for die t = 0,5		205A35			

ADDITIONAL ACCESSORIES			ADDITIONAL COSTS FOR STRIPPER			ADDITIONAL COSTS FOR DIES		
Assembly adapter		299201599	Polypunch			Reinforced		
						slug-snap		

PASS SYSTEM P10 (BLANK-HOLDER STYLE AND NEEDLE INSERT)

TYPE: 33 MM / 70 KN / P1 - P20

DIAMETER: UP TO 10,5 MM

	POS.-NO.	PART-NO.
UPPER PART		
Round	1-6	201661
Square	1-6	2016602
Rectangle	1-6	2016603
Oblong	1-6	2016604
O.D. Ground Special Shape	1-6	21566G
EDM Required Special Shape	1-6	21566E
PUNCH INSERT (SHAFT Ø 10,5 MM) (H-PM®)		
Round	4	207P10A1
Square	4	207P10A02
Rectangle	4	207P10A03
Oblong	4	207P10A04
O.D. Ground Special Shape	4	207P10AG
EDM Required Special Shape	4	207P10AE
ACTIVE STRIPPER		
Round	6+3	219661
Square	6+3	2196602
Rectangle	6+3	2196603
Oblong	6+3	2196604
O.D. Ground Special Shape	6+3	21966G
EDM Required Special Shape	6+3	21966E
STRIPPER		
Round 35 mm	7	210335
DIE (SLUG-STOP) (H-PM®)		
Round	8	206301
Square	8	2063002
Rectangle	8	2063003
Oblong	8	2063004
O.D. Ground Special Shape	8	21630G
EDM Required Special Shape	8	21630E

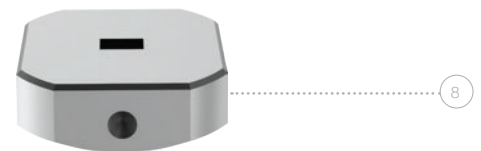
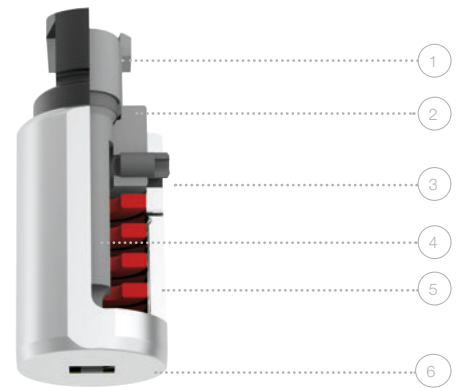

ADDITIONAL COSTS FOR PUNCH	SPARE PARTS		
TICN coating	Punch head	1+2	219671
T-MAX coating	Retaining screw	2	219666
A-MAX coating	Spring	5	219663
Cutting part under 1,00 mm	Special threadscrew	3	219665
	Shims for die t = 0,3		203A33
	Shims for die t = 0,5		205A35
ADDITIONAL COSTS FOR STRIPPER			
Polypunch			

ADDITIONAL COSTS FOR DIES	ADDITIONAL ACCESSORIES	
Reinforced slug-snap	Assembly adapter	299201599