

## 1216

**Mat = C45**  
bonificato / tempered

**H = 155.00**

**Max T/m = 50**

**$\alpha = 85^\circ$**

**R = 1.5**

|                          |         |
|--------------------------|---------|
| 1000 mm                  | 30,0 kg |
| 500 mm                   | 15,0 kg |
| 1100 mm<br>FRAZ. / SECT. | 30,0 kg |
| 100 mm                   | 3,0 kg  |

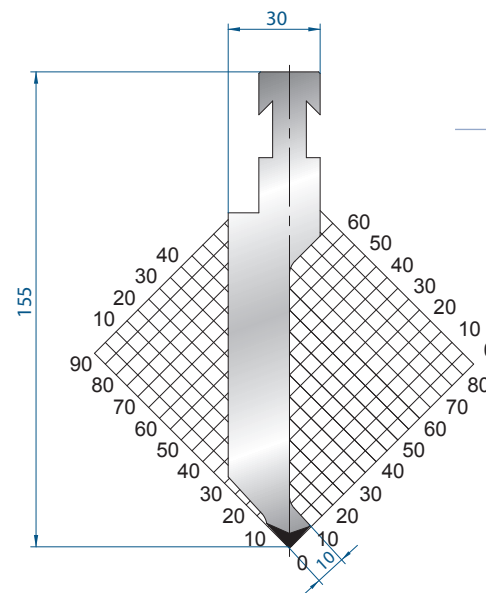

## 1218

**Mat = C45**  
bonificato / tempered

**H = 155.00**

**Max T/m = 100**

**$\alpha = 85^\circ$**

**R = 1**

|                          |         |
|--------------------------|---------|
| 1000 mm                  | 23,0 kg |
| 500 mm                   | 12,5 kg |
| 1100 mm<br>FRAZ. / SECT. | 30,0 kg |
| 100 mm                   | 3,0 kg  |



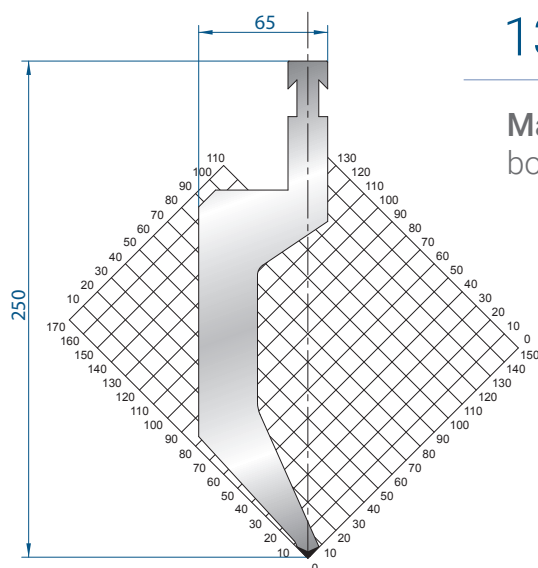

1321

**Mat** = 42CrMo4  
bonificato / tempered

**H** = 250.00

**Max T/m** = 100

**$\alpha$**  = 85°

**R** = 1.5

|                          |         |
|--------------------------|---------|
| 500 mm                   | 27,9 kg |
| 1100 mm<br>FRAZ. / SECT. | 61,0 kg |
| 100 mm                   | 5,6 kg  |

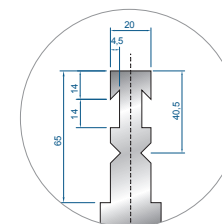

ATTACCO RF-A  
INCLUSO SU RICHIESTA  
RF-A TANG INCLUDED  
ON DEMAND