

3086

Mat = C45
Max T/m = 100
 $\alpha = 85^\circ$

835 mm	13,0 kg
415 mm	6,0 kg
805 mm FRAZ. / SECT.	13,0 kg

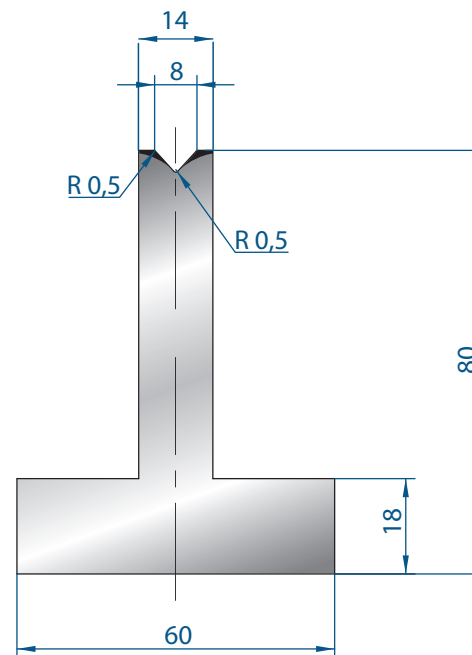

3087

Mat = C45
Max T/m = 100
 $\alpha = 85^\circ$

835 mm	13,0 kg
415 mm	6,0 kg
805 mm FRAZ. / SECT.	13,0 kg

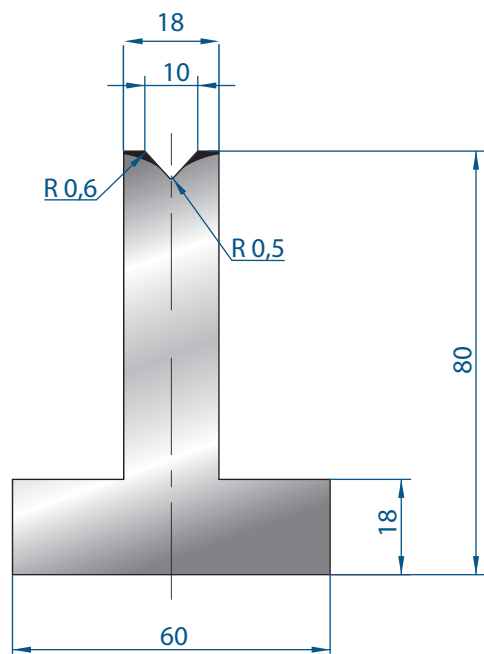

3088

Mat = C45
Max T/m = 100
 $\alpha = 85^\circ$

835 mm	13,0 kg
415 mm	6,0 kg
805 mm FRAZ. / SECT.	13,0 kg

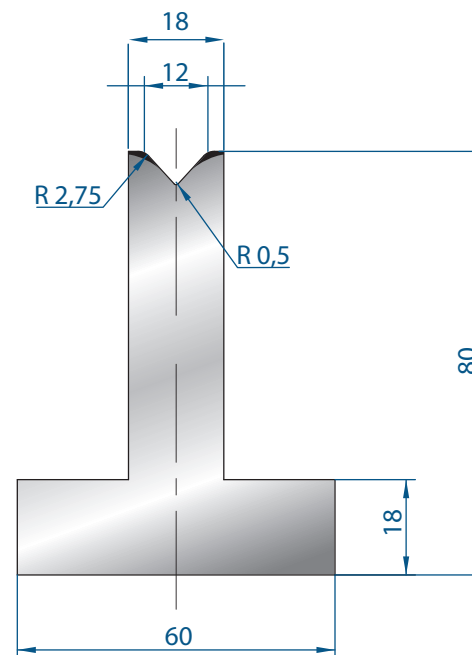

3089

Mat = C45
Max T/m = 100
 $\alpha = 85^\circ$

835 mm	13,0 kg
415 mm	6,0 kg
805 mm FRAZ. / SECT.	13,0 kg



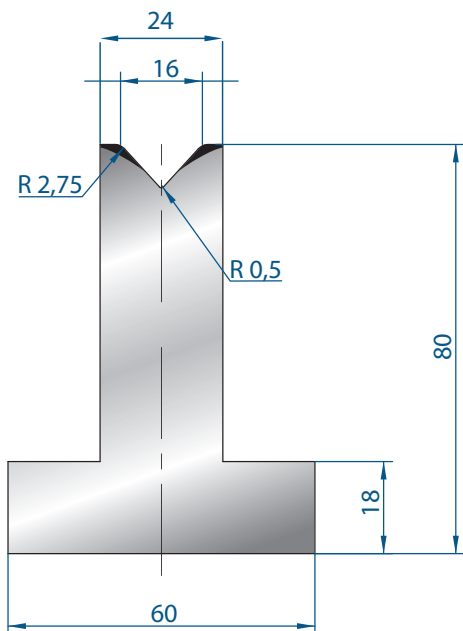

3090

Mat = C45
Max T/m = 100
 $\alpha = 85^\circ$

835 mm	13,0 kg
415 mm	6,0 kg
805 mm FRAZ. / SECT.	13,0 kg

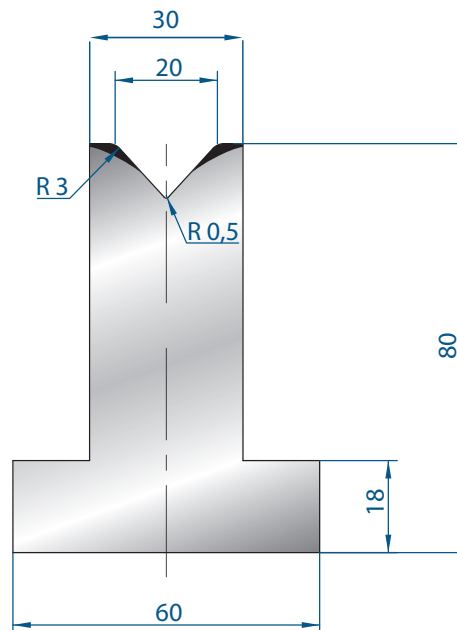

3091

Mat = C45
Max T/m = 100
 $\alpha = 85^\circ$

835 mm	13,0 kg
415 mm	6,0 kg
805 mm FRAZ. / SECT.	13,0 kg

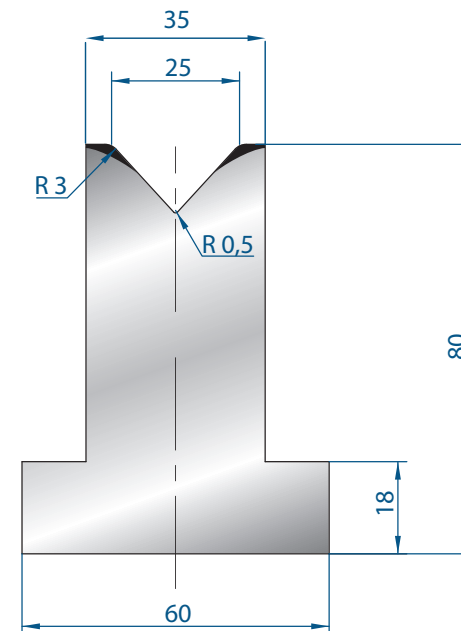

3092

Mat = C45
Max T/m = 100
 $\alpha = 85^\circ$

835 mm	13,0 kg
415 mm	6,0 kg
805 mm FRAZ. / SECT.	13,0 kg

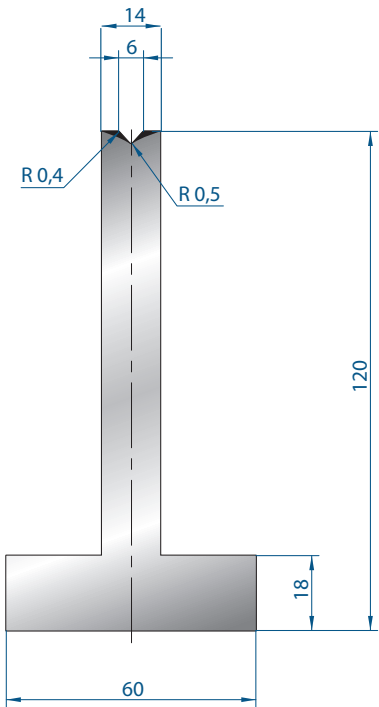

3093

Mat = C45
Max T/m = 100
 $\alpha = 85^\circ$

835 mm	17,0 kg
415 mm	8,0 kg
805 mm FRAZ. / SECT.	17,0 kg

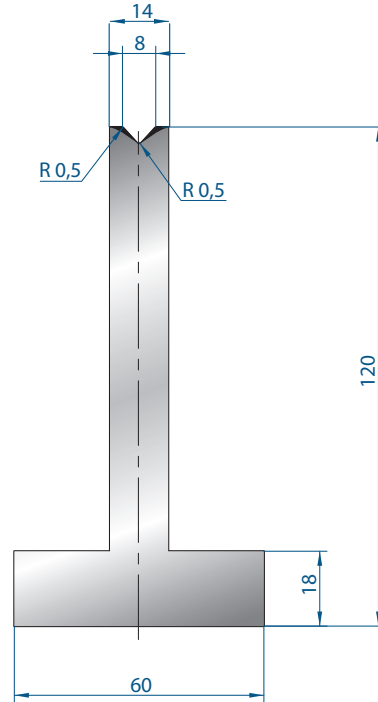

3094

Mat = C45
Max T/m = 100
 $\alpha = 85^\circ$

835 mm	17,0 kg
415 mm	8,0 kg
805 mm FRAZ. / SECT.	17,0 kg

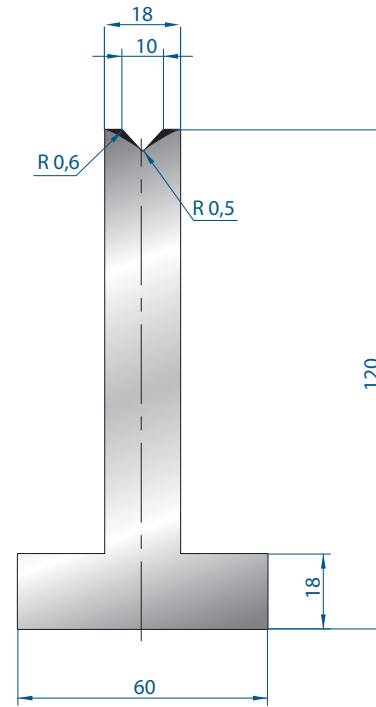

3095

Mat = C45
Max T/m = 100
 $\alpha = 85^\circ$

835 mm	18,0 kg
415 mm	9,0 kg
805 mm FRAZ. / SECT.	18,0 kg

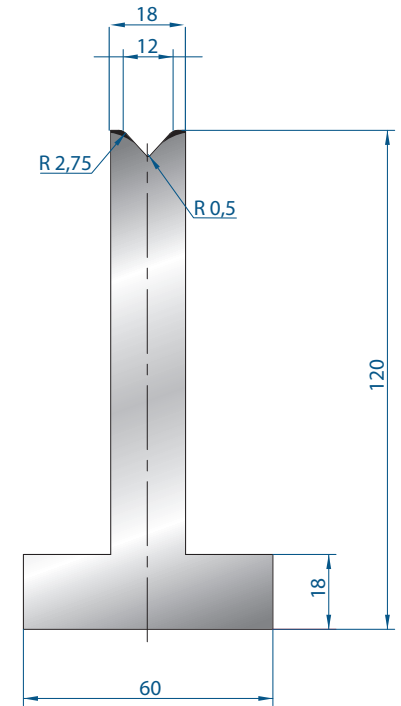

3096

Mat = C45
Max T/m = 100
 $\alpha = 85^\circ$

835 mm	18,0 kg
415 mm	9,0 kg
805 mm FRAZ. / SECT.	18,0 kg



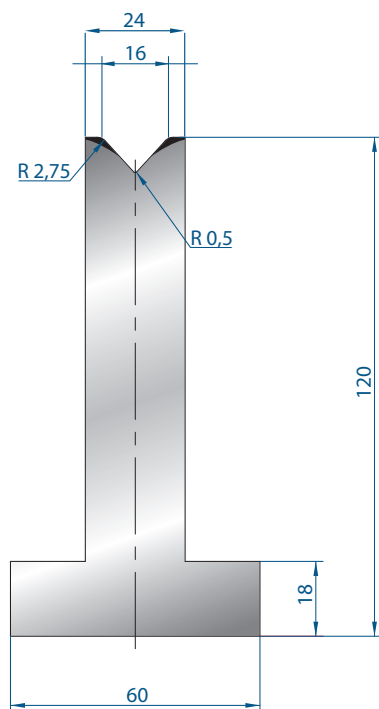

3097

Mat = C45
Max T/m = 100
 $\alpha = 85^\circ$

835 mm	22,0 kg
415 mm	11,0 kg
805 mm FRAZ. / SECT.	22,0 kg

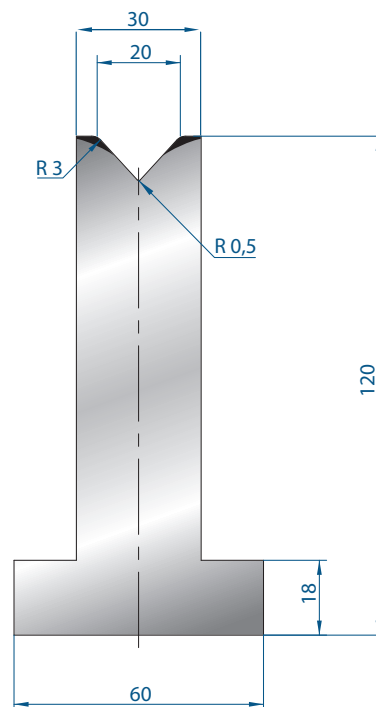

3098

Mat = C45
Max T/m = 100
 $\alpha = 85^\circ$

835 mm	27,0 kg
415 mm	13,0 kg
805 mm FRAZ. / SECT.	27,0 kg

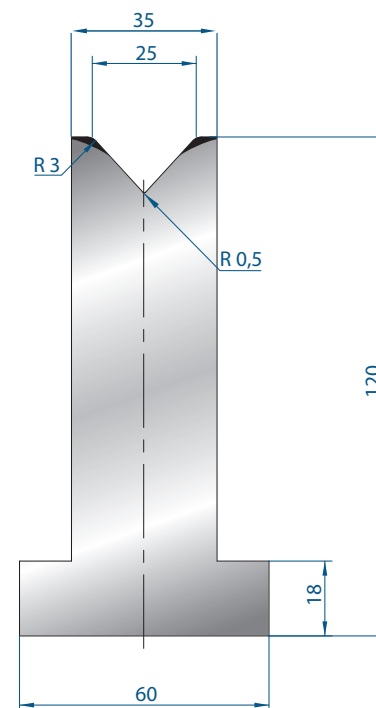

3099

Mat = C45
Max T/m = 100
 $\alpha = 85^\circ$

835 mm	13,0 kg
415 mm	5,0 kg
805 mm FRAZ. / SECT.	13,0 kg

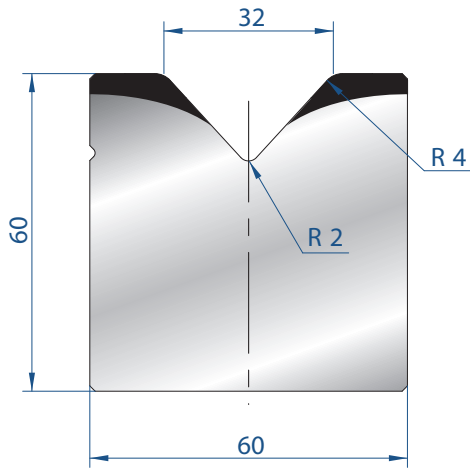

2020

Mat = C45
Max T/m = 100
 $\alpha = 85^\circ$

835 mm	22,0 kg
415 mm	11,0 kg
805 mm FRAZ. / SECT.	22,0 kg

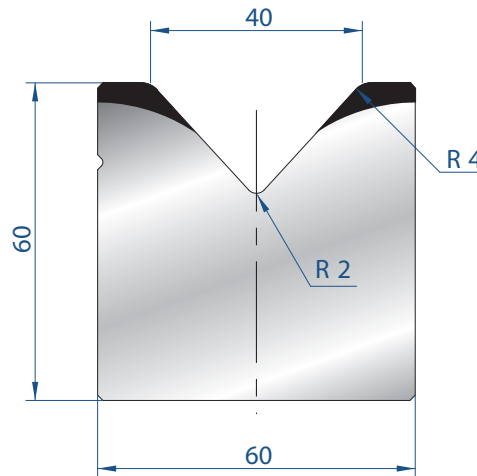

2021

Mat = C45
Max T/m = 100
 $\alpha = 85^\circ$

835 mm	21,0 kg
415 mm	10,0 kg
805 mm FRAZ. / SECT.	21,0 kg

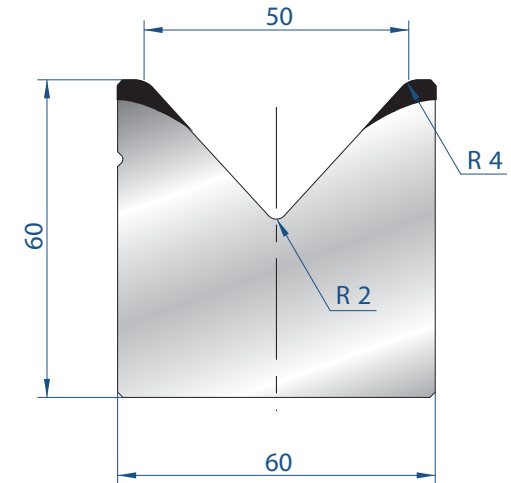

2022

Mat = C45
Max T/m = 80
 $\alpha = 85^\circ$

835 mm	19,0 kg
415 mm	9,0 kg
805 mm FRAZ. / SECT.	19,0 kg



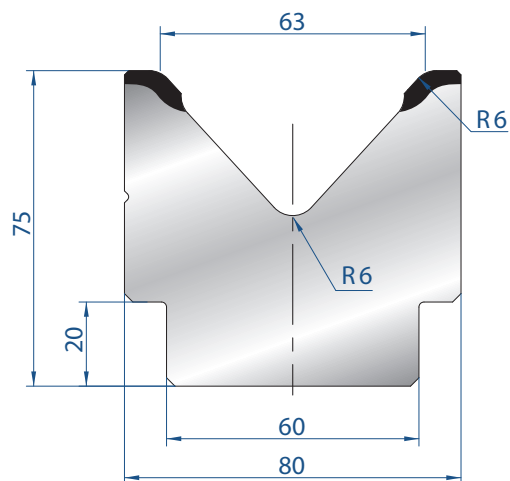

2023

Mat = C45
Max T/m = 100
 $\alpha = 85^\circ$

835 mm	28,5 kg
415 mm	15,0 kg
805 mm FRAZ. / SECT.	28,5 kg

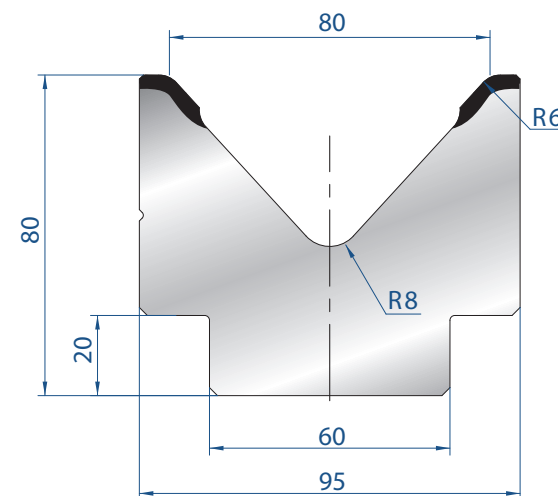

2024

Mat = C45
Max T/m = 100
 $\alpha = 85^\circ$

835 mm	38,0 kg
415 mm	19,0 kg
805 mm FRAZ. / SECT.	38,0 kg